

Absolute encoders - bus interfaces

Ex approval Ex II 2D/2G (ATEX)

Optical multiturn encoders 13 bit ST / 16 bit MT

X 700 - Profibus



X 700 with Profibus

Features

- Encoder multiturn / Profibus / ATEX
- Optical sensing method
- Resolution: singleturn 13 bit, multiturn 16 bit
- Clamping flange with solid shaft $\varnothing 10$ mm
- Explosion protection per Ex II 2D/2G (ATEX)
- Device class 2 / zone 1 (gas), zone 21 (dust)
- Maximum resistant against magnetic fields

Technical data - electrical ratings

Voltage supply	10...30 VDC
Reverse polarity protection	Yes
Consumption w/o load	≤ 100 mA (24 VDC)
Initializing time typ.	250 ms after power on
Interface	Profibus-DPV0
Function	Multiturn
Device adress	Rotary switch in bus cover
Steps per turn	≤ 8192 / 13 bit
Number of turns	≤ 65536 / 16 bit
Absolute accuracy	$\pm 0.025^\circ$
Sensing method	Optical
Code	Binary
Code sequence	CW/CCW programmable
Interference immunity	DIN EN 61000-6-2
Emitted interference	DIN EN 61000-6-4
Programmable parameters	Operating modes Total resolution Scaling Rotation speed monitoring
Diagnostic functions	Position or parameter error Multiturn sensing

Technical data - mechanical design

Size (flange)	$\varnothing 70$ mm
Shaft type	$\varnothing 10$ mm solid shaft (clamping flange)
Flange	Clamping flange
Protection DIN EN 60529	IP 67
Operating speed	≤ 6000 rpm (mechanical) ≤ 6000 rpm (electric)
Starting acceleration	≤ 1000 U/s ²
Starting torque	≤ 0.4 Nm (+25 °C)
Admitted shaft load	≤ 60 N axial ≤ 50 N radial
Materials	Housing: stainless steel Flange: stainless steel
Operating temperature	-25...+60 °C
Relative humidity	95 % non-condensing
Resistance	DIN EN 60068-2-6 Vibration 10 g, 16-2000 Hz DIN EN 60068-2-27 Shock 200 g, 6 ms
Explosion protection	Ex II 2G Ex d IIC T6 Ex II 2D
Weight approx.	1500 g
Connection	Bus cover

Absolute encoders - bus interfaces

Ex approval Ex II 2D/2G (ATEX)

Optical multiturn encoders 13 bit ST / 16 bit MT

X 700 - Profibus

Part number

X 700.P **1** **1** **3P33**

		<u>Interface</u>
	3P33	Profibus-DPV0 / cable gland
		<u>Voltage supply / signals</u>
1	10...30 VDC / 13 + 16 bit	
		<u>Flange / Solid shaft</u>
1	Clamping flange / ø10 mm, IP 67	

CD with file descriptions is not included in the delivery. You may order them on CD as accessory.

Accessories

Programming accessories

Z 150.022 CD with describing files & manuals

Profibus-DP features

Bus protocol	Profibus-DPV0
Device profile	Device Class 1 and 2
Cyclic data exchange	Communication in line with DPV0
Input data	Position value. In addition optionally speed signal parametering (output of current rotation speed).
Output data	Preset
Preset	Parameter for setting the encoder to a requested position value assigned to a defined shaft position of the system. Storage non-volatile.
Rotating direction	Parameter for defining the rotating direction in which there have to be ascending or descending position values.
Scaling	Parameter defining the steps per turn as well as the total resolution.
Diagnosis	The encoder supports the following error warnings: <ul style="list-style-type: none">- Position and parameter error- Lithium battery voltage control (Multiturn)
Default	User address 00 Termination OFF

Absolute encoders - bus interfaces

Ex approval Ex II 2D/2G (ATEX)

Optical multiturn encoders 13 bit ST / 16 bit MT

X 700 - Profibus

View inside bus cover

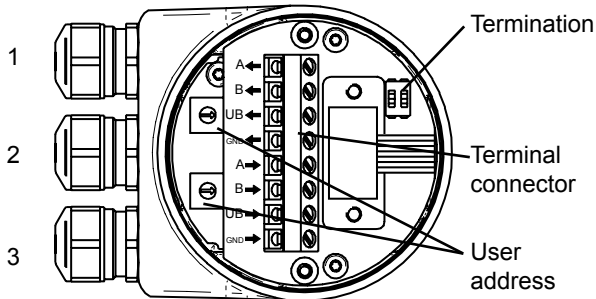

Cable: 1, 2 = Ø5...10 mm (Profibus) / 3 = Ø3...6.5 mm (UB)

Terminal assignment

Cable gland

UB	Voltage supply 10...30 VDC
GND	Ground connection relating to UB
A	Negative data line
B	Positive data line

Terminals of the same significance are internally connected and identical in their functions. Max. load on the internal terminal connections UB-UB and GND-GND is 1 A each.

Termination

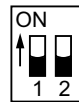

both ON = final user
both OFF = user X

User address (identifier)

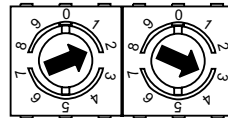

Defined by rotary switch.
Example: User address 23

Dimensions

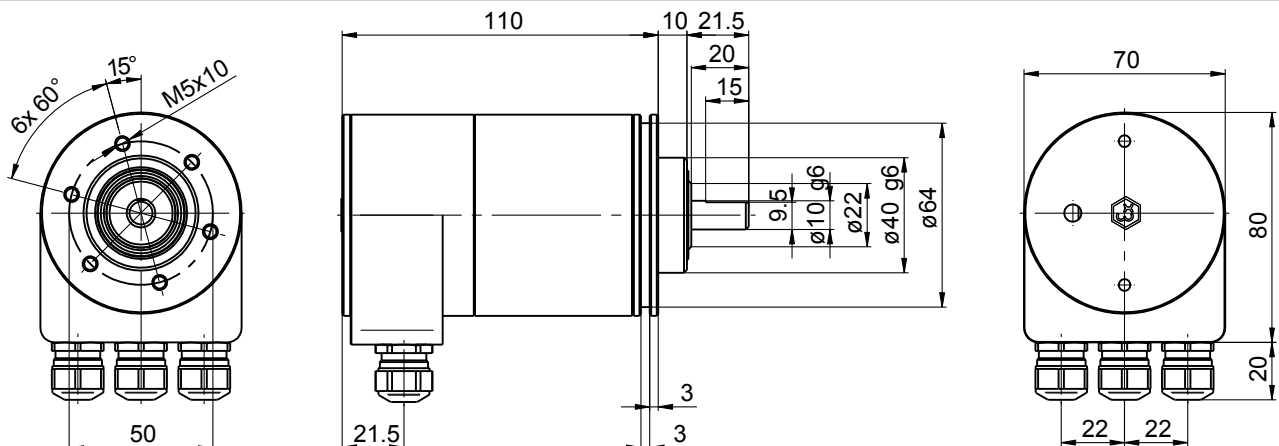

The electrical outlet may provide a $\pm 15^\circ$ shift to the bore pattern

Absolute encoders - bus interfaces

Ex approval Ex II 2D/2G (ATEX)

Optical multiturn encoders 13 bit ST / 16 bit MT

X 700 - Profibus

Check list for EX-approval

In compliance with EU standards 94/9/EG for potentially explosive areas it is imperative that the present checklist is duly completed and that all pending questions relating to explosion protection and application are clarified.

Company: _____
Address: _____
Division: _____
In charge: _____
Phone: _____ Fax: _____
e-mail: _____

Product name:	Version:	Resolution (ppr / code):	Supply voltage:
Kind of e-connection:	Length of cable (m):	Output circuit:	Special options:

Responsibility

- Our customer will receive all relevant information to verify a correct application.
- Our customer has to clarify all relevant criterions and characteristics.
- The operator shall be responsible for not exceeding the maximum performance limits of our devices (see data sheet).

Device utilization/application (E.g.: Lacquering line, manufacturing tech., gas storing vessel etc.)

Device group, device category and zone classification

Device group		please tick
Device group I		<input type="checkbox"/>
Device group II		<input type="checkbox"/>
Category / Zone	Ex-atmosphere prevailing	
Category 1 (= Zone 0/20)	... permanently, long-term or frequently	<input type="checkbox"/>
Category 2 (= Zone 1/21)	... only now and then	<input type="checkbox"/>
Category 3 (= Zone 2/22)	... rarely or seldom	<input type="checkbox"/>
Zone classification		
G (gases)	Zone 0, zone 1, zone 2	<input type="checkbox"/>
D (dusts)	Zone 20, zone 21, zone 22	<input type="checkbox"/>

Absolute encoders - bus interfaces

Ex approval Ex II 2D/2G (ATEX)

Optical multiturn encoders 13 bit ST / 16 bit MT

X 700 - Profibus

Check list for EX-approval

Ignition protection

please tick

Ex d	Flameproof (pressure-proof capsule)	<input type="checkbox"/>
Ex ia	Intrinsic safety	<input type="checkbox"/>
Ex ib	Intrinsic safety	<input type="checkbox"/>

Gas explosion group

Gases are classified into explosion groups. Danger increases from group II A to II C. please tick

II A	Propane	<input type="checkbox"/>
II B	Ethylene	<input type="checkbox"/>
II C	Hydrogen, Acetylene	<input type="checkbox"/>

Temperature classes and groups of explosion

Temperature class	Max. surface temperature of operating equipment (°C)	Max. ignition temperature of combustible substances (°C)	please tick
T1	450	> 450	void
T2	300	>300...< 450	void
T3	200	>200...< 300	void
T4 (on request)	135	>135...< 200	<input type="checkbox"/>
T5	100	>100...< 135	void
T6	85	> 85...< 100	<input type="checkbox"/>

Information on ambient and operating temperature

Expected operating temperature:	to be clarified
Field ambient temperature:	to be clarified

Mechanical strain

Rotation speed (rpm)
Axial shaft load (N)
Radial shaft load (N)
Ambient impacts (salt, lye, etc.)

Date

Signature

Stamp:

Date

Release EExB / trained sales